

**Hypertext Index**  
**WWII Allied And Axis Aircraft**  
**1/72nd Scale 3-View Drawings**  
**Version 1.0 12/30/95**

**COPYRIGHT NOTICE**

You have permission to copy and distribute this file or program, as supplied and without change, provided that there is **NO charge or surcharge**, other than for normal download time. **If you charge to distribute this file you MUST get written permission from the author.**

Please see the [Copyright & Fair Use](#) notice in this publication for specific details.

**CLICK PAGE TO VIEW BOOK**



**FLY'N THINGS™**

**WWII Combat Aircraft 3-Views  
Hypertext Index & Samples**

- Welcome!**
- Plan-Code Types**
- Sample Plan-Code Types - Side Views**
- Index By Country**
- Index By Manufacturer**
- Printing Problems**
- Copyright And Fair Use**
- Warranty**
- Order Information**
- Terms Of Sale**
- 3-View Drawing Order Blank**
- Other FLY'N THINGS™ Products**



# WELCOME!

This is a hypertext index to the over 500 1/72nd-Scale 3-view drawings available in computer format. All drawings are in bitmap format, scanned with a calibrated, flatbed, HP ScanJet Plus. Our standard file format is a monochrome PCX file for use with the **FLY'N THINGS™** PCX-To-DXF Conversion program for Microsoft Windows™ 3.1, 3.11 and Windows 95™.

Samples of various types of WWII aircraft from around the world are included. These can be printed on regular letter-size paper used by most computer printers.

This **Version 1.0** of the **WWII Hypertext Index** has 40 3-view drawings in the attached file. These samples can be viewed and printed. Samples you can view/print are indicated by underlined hyper-text links in the aircraft listings. The sheet-number and type designation for these sample drawings are preceded by an asterisk (\*). Use the Adobe™ Acrobat™ Reader's Search function to find them.

The drawings and hypertext index are in separate files. As more 3-view samples are released, just download the new samples and update to the latest version of this index.

[\*\*☐ Table Of Contents\*\*](#)



# WWII Allied And Axis Aircraft Over 500 Types From 12 Countries 1/72 Scale 3-View Drawings

## Plan Codes:

**\$US Per Drawing**

①	Detail Panel Markings And Structure; Original Drawing Is One 8-1/2 x 11 Sheet.....	<b>10.00</b>
②	Detail Panel Markings And Structure; Original Drawing Is Two 8-1/2 x 11 Sheets.....	<b>15.00</b>
③	Detail Panel Markings And Structure; Original Drawing Is Three 8-1/2 x 11 Sheets.....	<b>20.00</b>
①	Basic Outlines Only - No Detail Panel Markings; One 8-1/2 x 11 Sheet.....	<b>10.00</b>
②	Basic Outlines Only - No Detail Panels; Original Drawing Is Two 8-1/2 x 11 Sheets.....	<b>15.00</b>
③	Basic Outlines Only - No Detail Panels; Original Drawing Is Three 8-1/2 x 11 Sheets.....	<b>20.00</b>

## NOTES:

1. All Multiple-Sheet Drawings Are Combined Into ONE 11 x 17 Sheet At Reduced Size.
2. Early Drawings Marked As Basic Outlines Do Include Control Surfaces And Major Structure Points. Many Of The Later Aircraft Basic-Outline Drawings DO Include Reasonable Fuselage Detail.
3. ALL Drawings Have A "Scale" Ruler And Include Airfoil And Fuselage Sections.
4. Drawings Followed By "SPLIT" Are Reduced -Size, And Split Across Two Pages. We Cannot Guarantee That The Two Parts Will Be An Exact Match - ORDER ONLY IF IT'S THE ONLY DRAWING YOU CAN FIND.

 **Table Of Contents**



# WWII Allied And Axis Aircraft 1/72nd Scale 3-View Drawings

## ORDER INFORMATION

Payments & Orders To:

**Phil Koopman**

**2805 Hunt Club Lane**

**Orlando, FL 32826-3909 U.S.A.**

**(407) 381-9464 Afternoons & Evenings E.S.T.**

**Internet E-Mail: [pkaronaut@aol.com](mailto:pkaronaut@aol.com)**

**WWW: <http://users.aol.com/pkaeronaut/pkaero.html>**

## COST:

For E-Mail Orders and uploads to AOL Members of a 3-View drawing the cost is \$10 US for a single 8-1/2 x 11 inch page. Each additional drawing page is \$5.00 US. All two- and three-page drawings are combined into a single, reduced-size, 11 x 17 drawing.

For mail orders, the cost for the basic 3-View Drawing is US\$10.00, with US\$5.00 for each additional drawing page. Add US\$3.50 for shipping and handling per order. Our standard disk is a 1.44-Mbyte (HD), 3-1/2-in. floppy disk. U.S. shipment is by Priority Mail. **PLEASE SPECIFY WHAT SIZE DISK if ordering by mail!**

We will try our best to supply special disk formats for IBM-Compatible software. Let us know what you need and we'll convert the files with any format available for Micrografx's Picture Publisher 5.0. There are two standard sets; All uncompressed TIF files at 300 dpi. And, the CAD set with 300-dpi 3-View drawing for use with our PCX-to-DXF conversion program.

For our overseas friends, please contact us for the shipping costs. We can transmit via InterNet E-Mail with ZIPPed UUENCODEd files compatible with PCs and Unix systems. Please remember that these files are large and take a good deal of time to transmit. In ZIPPed format, a single one-sheet set is about 700 kbytes. Our Internet Gateway presently limits us to about 1-Mbyte files, so a typical set may come to you in parts. Transmit time presently costs \$3.00 per hour at 28.8 kbaud.

## TERMS:

We will copy/scan your order when received by E-Mail; upload is done when we receive your payments in cash or Money Order. All payments must be US Dollars. Sorry, no personal or company checks accepted. The same terms apply to mail orders. If the aircraft is already scanned, we try and upload/ship in 48 hours. But please allow two weeks total time for delivery, as many of these plans must be carefully scanned and restored.

All images are copyrighted. Permission is granted ONLY for non-commercial personal use. All rights reserved, including file/disk duplication in any form, mechanical or electronic or printed. They may not be duplicated in any form for sale. If you wish to use the 3-views for plan documentation, like a Peanut-Scale model plan, contact us and we'll be happy to work something out. Please see our [Fair Use and Copyright Notice](#).

Please honor the Personal-Use Copyright Notice. We are trying to supply a low-cost service; if our new scanned files are passed around, we probably won't be around to supply you! Our goal is to make hard-to-get data available to all modelers — not just those with the big bucks that can afford to pay hundreds of dollars for collector's books.

Thanks

Phil

# Copyright And Fair Use

All images are copyrighted. Permission is granted **ONLY for non-commercial personal use**. They may not be duplicated in any form, including electronic, mechanical or printed, for sale. All rights are reserved and duplication by any means, including, but not limited to, methods of printing, electronic storage and disk copies, is prohibited without permission.

**These File(s) MAY NOT BE PUT ON A SYSTEM IN A DOWNLOAD AREA SUBJECT TO A SURCHARGE!**

**IF YOU PAID A DOWNLOAD FEE, OTHER THAN NORMAL LINE CHARGES, DEMAND YOUR MONEY BACK! YOU HAVE BEEN RIPPED OFF BY THOSE THAT COPY OTHER PEOPLE'S INTELLECTUAL PROPERTY AND SELL IT WITHOUT PERMISSION OR PAYMENT TO THE AUTHOR. CHARGES TO DOWNLOAD THIS FILE/PROGRAM ARE CONTRARY TO THE COPYRIGHT!**

Only the **SAMPLE FILES** and a **REGISTERED file WITHOUT the ACCESS CODE** may be freely distributed, provided the Copyright notice remains intact. **You may NOT duplicate, sell or give away, in any form, your ACCESS Code for a Registered version.**

**IF YOU UPLOAD TO ANY OTHER COMPUTER, MAKE A DISK COPY FOR A FRIEND, ETC., THE ENTIRE SAMPLE PDF/ZIP FILE AND ANY ACCOMPANYING DATA, AS SUPPLIED, MUST NOT BE MODIFIED OR CHANGED IN ANY WAY!**

**Table Of Contents**

**SHAREWARE DEALERS/DISTRIBUTORS PLEASE CONTACT ME FOR WRITTEN PERMISSION PRIOR TO MAKING OR DISTRIBUTING ANY COPY(S) OF THIS SOFTWARE.**

Only the copyright owner, Phil Koopman, Sr. and/or **FLY'N THINGS™**, can give permission for copies to be made. Permission is granted for disk copies to be made freely for 30-day evaluation purposes, provided that they are marked as Shareware and do not include a License Data File or Access Code.

**Please honor the Personal-Use Copyright Notice.** We are trying to supply a low-cost service. Our goal is to make low-cost models and information available to all modelers. — not just those with the big bucks that can afford to pay for commercial models, plans or rare books.

**Phil Koopman, Sr.  
2805 Hunt Club Lane  
Orlando, FL 32826-3909  
Voice: (407) 381-9464**

**America On Line: PKAeronaut  
Internet: pkaeronaut@aol.com  
<http://users.aol.com/pkaeronaut/pkaero.html>**

**Please see: [Warranty](#)**

**MORE** 

## Warranty

THE PROGRAM IS PROVIDED AS IS. NO OTHER WARRANTIES OF ANY KIND, EXPRESS OR IMPLIED, ARE MADE AS TO IT OR ANY MEDIUM IT MAY BE ON. FLY'N THINGS™ AND/OR PHIL KOOPMAN, SR. DISCLAIM ALL OTHER WARRANTIES, EITHER EXPRESSED OR IMPLIED, INCLUDING BUT NOT LIMITED TO IMPLIED WARRANTIES OF MERCHANTABILITY AND FITNESS FOR A PARTICULAR PURPOSE, WITH RESPECT TO THE SOFTWARE AND THE ACCOMPANYING WRITTEN OR GRAPHIC MATERIALS. THIS LIMITED WARRANTY GIVES YOU SPECIFIC LEGAL RIGHTS. YOU MAY HAVE OTHERS, WHICH VARY FROM STATE/JURISDICTION TO STATE/JURISDICTION.

NO LIABILITY FOR CONSEQUENTIAL DAMAGES. IN NO EVENT SHALL FLY'N THINGS™ AND/OR PHIL KOOPMAN, SR. OR ITS SUPPLIERS BE LIABLE FOR ANY

DAMAGES WHATSOEVER (INCLUDING, WITHOUT LIMITATION, PERSONAL INJURY, DAMAGES FOR LOSS OF BUSINESS PROFITS, BUSINESS INTERRUPTION, LOSS OF BUSINESS INFORMATION, OR OTHER PECUNIARY LOSS) ARISING FROM THE USE OR THE INABILITY TO USE THIS FLY'N THINGS™ PRODUCT, EVEN IF FLY'N THINGS™ AND/OR PHIL KOOPMAN, SR. HAVE BEEN ADVISED OF THE POTENTIAL OF SUCH DAMAGES. BECAUSE SOME STATES DO NOT ALLOW THE EXCLUSION OR LIMITATION OF LIABILITY FOR CONSEQUENTIAL OR INCIDENTAL DAMAGES, THE ABOVE LIMITATION MAY NOT APPLY TO YOU.

[❏ Table Of Contents](#)

[MORE](#) 

# Order Blank **FLY'N THINGS™** Products

Prices Effective 1 November 1995  
Prices Subject To Change Without Notice  
Print Out This Form

## WWII Allied And Axis Aircraft 1/72nd Scale 3-View Drawings

### Plan Codes:

### \$US Per Drawing

①	Detail Panel Markings And Structure; Original Drawing Is One 8-1/2 x 11 Sheet.....	10.00
②	Detail Panel Markings And Structure; Original Drawing Is Two 8-1/2 x 11 Sheets.....	15.00
③	Detail Panel Markings And Structure; Original Drawing Is Three 8-1/2 x 11 Sheets.....	20.00
①	Basic Outlines Only - No Detail Panel Markings; One 8-1/2 x 11 Sheet.....	10.00
②	Basic Outlines Only - No Detail Panels; Original Drawing Is Two 8-1/2 x 11 Sheets.....	15.00
③	Basic Outlines Only - No Detail Panels; Original Drawing Is Three 8-1/2 x 11 Sheets.....	20.00

### NOTES:

1. All Multiple-Sheet Drawings Are Combined Into ONE 11 x 17 Sheet At Reduced Size.
2. Early Drawings Marked As Basic Outlines Do Include Control Surfaces And Major Structure Points. Many Of The Later Aircraft Basic-Outline Drawings DO Include Reasonable Fuselage Detail.
3. ALL Drawings Have A "Scale" Ruler And Include Airfoil And Fuselage Sections.
4. Drawings Followed By "SPLIT" Are Reduced -Size, And Split Across Two Pages. We Cannot Guarantee That The Two Parts Will Be An Exact Match - ORDER ONLY IF IT'S THE ONLY DRAWING YOU CAN FIND.

### CASH INVOICE: (Please Print Clearly)

Name: \_\_\_\_\_

Address: \_\_\_\_\_  
\_\_\_\_\_  
\_\_\_\_\_

Please give your Email address: \_\_\_\_\_

Please List 3-Views You Are Ordering:

Aircraft	No. Sheets	\$US PRICE
_____	_____	_____
_____	_____	_____
_____	_____	_____
_____	_____	_____
_____	_____	_____

\$US TOTAL FOR Drawing(s): \_\_\_\_\_

### U.S.A. & Canada:

Shipping & Handling PER ORDER **US\$3.50**  
(For Overseas Orders, Please Contact Us For Costs)

3-1/2-Inch Disk Format: PC \_\_\_\_\_

Other (specify) Disk Format \_\_\_\_\_

Payment Enclosed (Sorry, No Checks; Cash Or Money)

Order Only: US\$ \_\_\_\_\_

*If sending cash, please send by Registered Mail for your protection. It's impossible for us to guarantee that we will receive your order.*

### PAYMENTS & MAIL TO:

Phil Koopman  
2805 Hunt Club Lane  
Orlando, FL 32826-3909  
(407) 381-9464 12:00 Noon 'Till 9:00PM E.S.T.

Internet E-Mail: [pkaeronaut@aol.com](mailto:pkaeronaut@aol.com)

WWW: <http://users.aol.com/pkaeronaut/pkaero.html>

Thank You :

Your order will be sent as rapidly as possible. If the drawing(s) have to be restored, please allow 2 weeks for processing.



# Order Blank **FLY'N THINGS™** Products

Prices Effective 1 November 1995  
Prices Subject To Change Without Notice  
Print Out This Form

CASH INVOICE: (Please Print Clearly)

Name:

Address:

**WWII The Pacific — Printed Book Pack**  
**Dime-Weight Flying Models & Instructions** US\$16.50  
Full-Color Printing;

Assembly Booklet with:  
Zero, Flying Tigers P-40, F6F Hellcat,  
Dauntless, Achi Val and Nakajima Oscar.  
Wingspan Approximately 7-1/2 Inches.

**WWII The Pacific - Acrobat™ PDF Book**  
**With Color and Monochrome Models**  
PDF Disk Version US\$16.50

**WWII The Pacific - Six MiniModel™, Printed**  
**Full-Color Book Pack** US\$7.50  
Assembly Booklet with:  
Zero, Flying Tigers P-40, F6F Hellcat,  
Dauntless, Achi Val and Nakajima Oscar.  
Wingspan Approximately 4-1/2 Inches.

**WWII The Pacific - Six MiniModel™ Acrobat™ PDF**  
**With Color and Monochrome Models**  
PDF Disk Version US\$7.50

**Gulf War: F117A Stealth Fighter/Bomber**  
**(Display Models)**  
Full-Color Printing:  
Large F-117A US\$4.98  
F-117A Postcard US\$1.97

**FLY'N THINGS™ Rigby's Flying Models — Book 1**  
**Monochrome Models Acrobat™ PDF Disk Contains:**  
Simple Glider Silhouettes:  
Bell Aircobra (U. S. A.)  
Fokker D21 (Holland)  
Hawker Hurricane (Britain)  
Built-up Three-Dimensional Models:  
Troop Carrying Glider, Thunderbolt Fighter, Piper Cub,  
Wellington Bomber, Douglas A20A Bomber, Northrop  
Flying Wing, Grumman F4F-3 Fighter  
E-Mail Registered PDF Disk Version US\$10.00  
Two-Disk Mailed PDF Version US\$15.00  
Or, Printed Book (Please Specity)

**Table Of Contents**

**FLY'N THINGS™ Rigby's Flying Models — Book 2**  
**Monochrome Models Acrobat™ PDF Disk Contains:**  
Simple Glider Silhouettes:  
TB-6B (Russian Bomber)  
M.E. 109 (Germany)  
Lightning (P38)  
Built-up Three-Dimensional Models:  
C-46 Curtiss Commando, U.S Troop Glider, Lancaster  
Heavy Bomber, Hurricane, F4U Corsair, P-51 Apache,  
Macchi C 202 Fighter  
E-Mail Registered PDF Disk Version US\$10.00  
Two-Disk Mailed PDF Version US\$15.00  
Or, Printed Book (Please Specity)

**New FLY'N THINGS™ Software For The CAD/Illustration**  
**Program User: PCX-To-DXF Conversion — Converts**  
monochrome PCX scanned images into an AutoCAD  
DXF file. "Dots" of the original PCX image are con-  
verted into DXF raster LINES. For Windows® 3.x and  
runs under Windows® 95. Shareware Program:

PCX-To-DXF Program Prices:

E-Mail Registration US\$20.00.  
Mailed Disk: US \$25.00

**Special Ink-Jet Paper & Card Stock**  
**For True Waterproof Printing**  
Card Stock: Ten(10) 8-1/2" x 11" Sheets US\$7.50  
Paper: Ten(10) 8-1/2" x 11" Sheets US\$5.00

**SAMPLE Pack - Three 8-1/2" x 11" Sheets of Card Stock**  
**& Sample Paper** US\$5.00 POSTPAID

U.S.A. & Canada:

Shipping & Handling PER ORDER US\$3.50  
(For Overseas Orders, Please Contact Us For Costs)  
3-1/2-Inch Disk Format: PC \_\_\_\_\_ Apple® \_\_\_\_\_

Payment Enclosed (Sorry, No Checks: Cash Or Money  
Order Only): US\$ \_\_\_\_\_

*If sending cash, please send by Registered Mail for your  
protection. It's impossible for us to guarantee that we will  
receive your order.*

Please give your Email address:

**PAYMENTS & MAIL TO:**  
Phil Koopman  
2805 Hunt Club Lane  
Orlando, FL 32826-3909  
(407) 381-9464

Thank You :

Your order will be sent by First Class Mail  
As Soon As Payment Is Received.

FORM PPOrder.PDF 11/1/95

**MORE** 

# Sample Types Of Plan Codes - Side Views

**Gloster Gladiator - Early Solid-Scale Model Drawing - BLACK Numbered Plan Code**

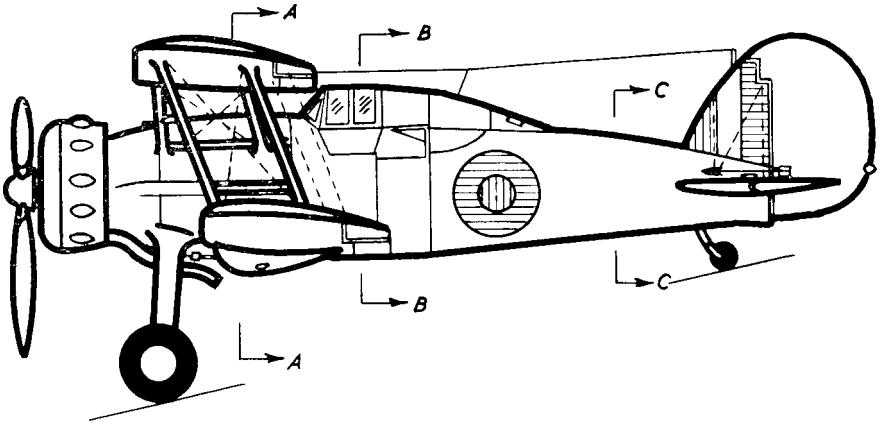

**Heinkel He 60 - Later Semi-Detailed Drawing - BLACK Numbered Plan Code**

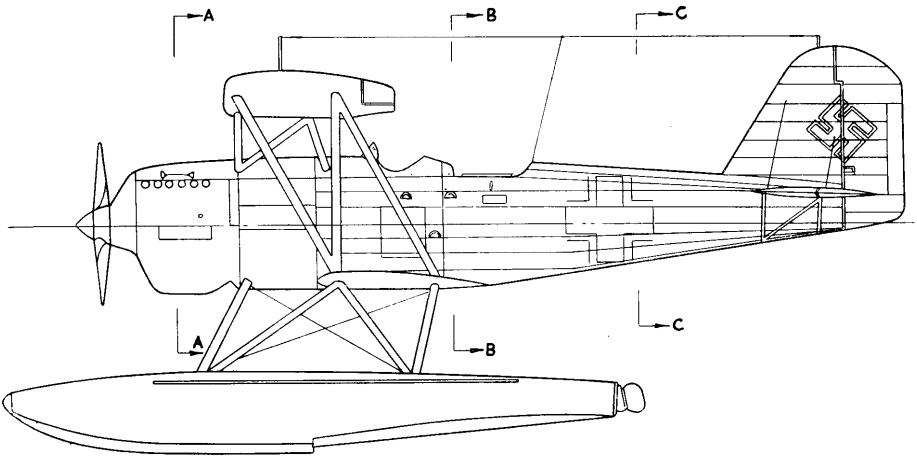

**Heinkel He 60 - Typical Fuselage Sections**

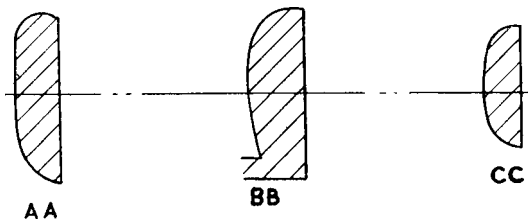

**Supermarine Spitfire XIV - Detailed Drawing - WHITE Numbered Plan Code**

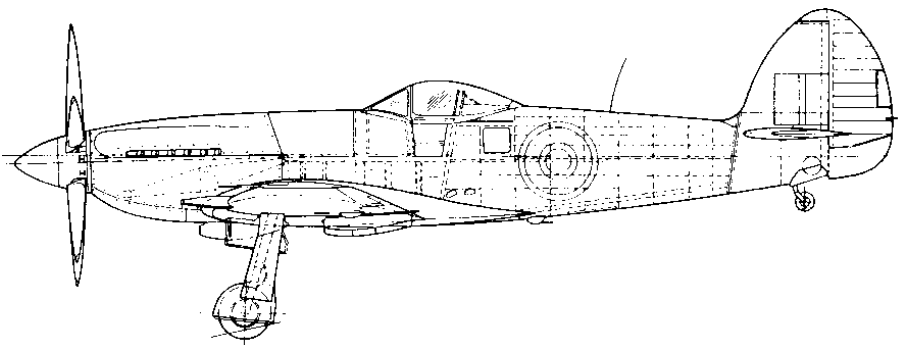

## Makers Index By Country

### Australia

COMMONWEALTH

### Belgium

FAIREY

### Canada

FLEET  
NOORDUYN

### France

BREGUET  
DEWOITINE  
LIORE ET OLIVIER  
MORANE SAULNIER  
POTEZ

### Germany

ARADO  
BACHEM  
BLOHM AND VOSS  
BUCKER  
D.F.S.  
DORNIER  
FIESELER  
FOCKE WULF  
GOTHA  
HEINKEL  
HENSCHEL  
JUNKERS  
MESSERSCHMITT  
SIEBEL

### Great Britain

AIRSPED  
ARMSTRONG WHITWORTH  
AUSTER  
AVRO  
BLACKBURN  
BOULTON PAUL  
BRISTOL  
DE HAVILLAND  
FAIREY  
GENERAL AIRCRAFT  
GLOSTER  
HANDLEY PAGE  
HAWKER  
MARTIN-BAKER  
MILES  
PERCIVAL  
SAUNDERS-ROE  
SHORT  
SLINGSBY  
SUPERMARINE See VICKERS

### Great Britain (Con't)

VICKERS ARMSTRONGS  
WESTLAND  
WICKO

### Holland

FOKKER  
KOOLHOVEN

### Italy

BREDA  
CANT  
CAPRONI  
CAPRONI-REGGIANE  
FIAT  
MACCHI  
PIAGGIO  
SAVOIA MARCHETTI

### Japan

AICHI  
Baka Kamikaze see FUJI KOKUKI K.K.  
FUJI KOKUKI K.K.  
KAWANISHI  
KAWASAKI  
MITSUBISHI  
NAKAJIMA  
SASEBO  
YOKOSUKA

### Poland

P.Z.L.

### Russia (U.S.S.R.)

RUSSIAN STATE FACTORIES

### U.S.A.

AERONCA  
BEECHCRAFT  
BELL  
BOEING  
BREWSTER  
CESSNA  
CHANCE VOUGHT  
CONSOLIDATED VULTEE  
CURTISS  
CURTISS-WRIGHT  
DOUGLAS  
FAIRCHILD  
FLEETWINGS  
GRUMMAN  
HALL  
HOWARD  
INTERSTATE  
KELLETT  
LOCKHEED

## U.S.A. (Con't)

MARTIN

MONOCOUBE

NAVAL AIRCRAFT FACTORY

NORTH AMERICAN

NORTHROP

PIPER

REPUBLIC

RYAN

SIKORSKY

SPARTAN

ST. LOUIS

STEARMAN

STINSON

TAYLORCRAFT

TIMM

VOUGHT-SIKORSKY

VULTEE

WACO

## Yugoslavia

IKARUS

# Index By Manufacturer

AERONCA (U.S.A.)  
AICHI (JAPAN)  
AIRSPPEED (GREAT BRITAIN)  
ARADO (GERMANY)  
ARMSTRONG WHITWORTH (GREAT BRITAIN)  
AUSTER (GREAT BRITAIN)  
AVRO (GREAT BRITAIN)  
BACHEM (GERMANY)  
BEECHCRAFT (U.S.A.)  
BELL (U.S.A.)  
BLACKBURN (GREAT BRITAIN)  
BLOHM AND VOSS (GERMANY)  
BOEING (U.S.A.)  
BOULTON PAUL (GREAT BRITAIN)  
BREDA (ITALY)  
BREGUET (FRANCE)  
BREWSTER (U.S.A.)  
BRISTOL (GREAT BRITAIN)  
BUCKER (GERMANY)  
CANT (ITALY)  
CAPRONI (ITALY)  
CAPRONI-REGGIANE (ITALY)  
CESSNA (U.S.A.)  
CHANCE VOUGHT (U.S.A.)  
COMMONWEALTH (AUSTRALIA)  
CONSOLIDATED VULTEE (U.S.A.)  
CURTISS (U.S.A.)  
CURTISS-WRIGHT (U.S.A.)  
DE HAVILLAND (GREAT BRITAIN)  
DEWOITINE (FRANCE)  
D.F.S. (GERMANY)  
DORNIER (GERMANY)  
DOUGLAS (U.S.A.)  
FAIRCHILD (U.S.A.)  
FAIREY (GREAT BRITAIN)  
FAIREY (BELGIUM)  
FIAT (ITALY)  
FIESELER (GERMANY)  
FLEET (CANADA)  
FLEETWINGS (U.S.A.)  
FOCKE WULF (GERMANY)  
FOKKER (HOLLAND)  
FUJI KOKUKI K.K. (JAPAN)  
GENERAL AIRCRAFT (GREAT BRITAIN)  
GLOSTER (GREAT BRITAIN)  
GOTHA (GERMANY)  
GRUMMAN (U.S.A.)  
HALL (U.S.A.)  
HANDLEY PAGE (GREAT BRITAIN)  
HAWKER (GREAT BRITAIN)  
HEINKEL (GERMANY)

HENSCHEL (GERMANY)  
HOWARD (U.S.A.)  
INTERSTATE (U.S.A.)  
IKARUS (YUGOSLAVIA)  
JUNKERS (GERMANY)  
KAWANISHI (JAPAN)  
KAWASAKI (JAPAN)  
KELLETT (U.S.A.)  
KOOLHOVEN (HOLLAND)  
LIORE ET OLIVIER (FRANCE)  
LOCKHEED (U.S.A.)  
MACCHI (ITALY)  
MARTIN (U.S.A.)  
MARTIN-BAKER (GREAT BRITAIN)  
MESSERSCHMITT (GERMANY)  
MILES (GREAT BRITAIN)  
MITSUBISHI (JAPAN)  
MONOCOUCPE (U.S.A.)  
MORANE SAULNIER (FRANCE)  
NAKAJIMA (JAPAN)  
NAVAL AIRCRAFT FACTORY (U.S.A.)  
NOORDUYN (CANADA)  
NORTH AMERICAN (U.S.A.)  
NORTHROP (U.S.A.)  
PERCIVAL (GREAT BRITAIN)  
PIAGGIO (ITALY)  
PIPER (U.S.A.)  
POTEZ (FRANCE)  
P.Z.L. (POLAND)  
REPUBLIC (U.S.A.)  
RUSSIAN STATE FACTORIES (U.S.S.R)  
RYAN (U.S.A.)  
SASEBO (JAPAN)  
SAUNDERS-ROE (GREAT BRITAIN)  
SAVOIA MARCHETTI (ITALY)  
SHORT (GREAT BRITAIN)  
SIEBEL (GERMANY)  
SIKORSKY (U.S.A.)  
SLINGSBY (GREAT BRITAIN)  
SPARTAN (U.S.A.)  
ST. LOUIS (U.S.A.)  
STEARMAN (U.S.A.)  
STINSON (U.S.A.)  
SUPERMARINE See VICKERS (GREAT BRITAIN)  
TAYLORCRAFT (U.S.A.)  
TIMM (U.S.A.)  
VICKERS ARMSTRONGS (GREAT BRITAIN)  
VOUGHT-SIKORSKY (U.S.A.)  
VULTEE (U.S.A.)  
WACO (U.S.A.)  
WESTLAND (GREAT BRITAIN)  
WICKO (GREAT BRITAIN)  
YOKOSUKA (JAPAN)

## AERONCA (U.S.A.)

- ① Aeronca L-3 Grasshopper (L-58B Defender)
- ① Aeronca TG-5 glider

## AICHI (JAPAN)

- ① Aichi Navy O (Jake)
- ① Aichi Navy Zuin (Paul)
- ① Aichi Navy 99 (Val)

## AIRSPED (GREAT BRITAIN)

- ② Airspeed Horsa I glider
- ① Airspeed Oxford I
- ① Airspeed Oxford IV & V

## ARADO (GERMANY)

- ① Arado Ar 95See
- ① Arado Ar 96B
- ① Arado Ar 196
- ② Arado Ar 232A - Split
- ① Arado Ar 234B
- ① Arado Ar 234C

## ARMSTRONG WHITWORTH (GREAT BRITAIN)

- ② Armstrong Whitworth Albemarle I & II
- ② Armstrong Whitworth Whitley III
- ② Armstrong Whitworth Whitley IV
- ② Armstrong Whitworth Whitley V

## AUSTER (GREAT BRITAIN)

- ① Auster Model D (British Taylorcraft D)
- ① Auster Model H glider
- ① Auster Mk II (British Taylorcraft Auster II)
- ① Auster Mk IV (British Taylorcraft Auster IV)
- ① Auster Mk VI

## AVRO (GREAT BRITAIN)

- ② Avro Anson I
- ① Avro Anson V & VI
- ① Avro Anson XIX & XII
- ③ Avro Lancaster I
- ② Avro Lancaster II - Split
- ③ Avro Lancaster III
- ③ Avro Lancastrian
- ② Avro Lincoln I & II - Split
- ③ Avro Manchester III

## Baka Kamikaze

see FUJI KOKUKI K.K. (JAPAN)

## BACHEM (GERMANY)

- ① Bachem Ba 349 Natter

## BEECHCRAFT (U.S.A.)

- \*① **Beech C-45A Expediter**
- ① Beech AT-7 Navigator & AT-11 Kansas
- ① Beech D17R (C-43)Traveller
- ① Beech At-10 Wichita

## BELL (U.S.A.)

- ① Bell Airacobra I (R.A.F.)
- \*① **Bell P-39Q Airacobra**
- ① Bell P-59A Airacomet
- ② Bell FM-1A Airacuda
- \*① **Bell RP-63 Kingcobra**

## BLACKBURN (GREAT BRITAIN)

- ② Blackburn B.20
- ② Blackburn Botha I
- ① Blackburn Firebrand IV
- ① Blackburn Roc I
- ① Blackburn Skua II

## BLOHM AND VOSS (GERMANY)

- ③ Blohm and Voss Bv 138B
- ② Blohm and Voss Bv 141B
- ③ Blohm and Voss Bv 142
- ① Blohm and Voss Bv 155b
- ② Blohm and Voss Bv 222 Viking
- ② Blohm and Voss Ha 139
- ② Blohm and Voss Ha 140
- ② Blohm and Voss Ha 142

## BOEING (U.S.A.)

- ② Boeing AT-15 Crewmaker
- ③ Boeing B-17C Fortress I
- ③ Boeing B-17E Fortress II
- ③ Boeing B-17G Fortress III
- ② Boeing C-98
- ② Boeing C-97 Stratocruiser - split
- ② Boeing B-29 Superfortress - Split
- ☐ Boeing-Stearman Caydet (see STEARMAN)

## BOULTON PAUL (GREAT BRITAIN)

- ① Boulton Paul Defiant I
- ① Boulton Paul Defiant III

## BREDA (ITALY)

- ① Breda 65
- ② Breda 88

## BREGUET (FRANCE)

- ② Breguet 691

## BREWSTER (U.S.A.)

- ① Brewster Bermuda I (R.A.F.)
- ① Brewster (F-2A-2) Buffalo I (R.A.F.)

## BRISTOL (GREAT BRITAIN)

- ② Bristol Beaufort I
- ② Bristol Beaufort II
- ① Bristol Beaufighter I
- ① Bristol Beaufighter II
- \*① **Bristol Beaufighter VI & X**
- ① Bristol Blenheim IV-F & IV-L
- ② Bristol Blenheim I
- ② Bristol Blenheim V
- ③ Bristol Bombay I
- ② Bristol Brigand I - Split
- ② Bristol Buckingham I - Split
- ② Bristol Buckmaster I - Split

## BUCKER (GERMANY)

- ① Bucker Bu 131B Jungmann
- ① Bucker Bu 181 Bestmann

## CANT (ITALY)

- ② Cant Z 501
- ② Cant Z 506B Airone
- ① Cant Z 1007bis Alcione

## CAPRONI (ITALY)

- ② Caproni Ca 133
- ② Caproni Ca 135bis
- ② Caproni Ca 310 Libeccio
- ② Caproni Ca 311
- ② Caproni Ca 312bis

## CAPRONI-REGGIANE (ITALY)

- ① Caproni-Reggiane R.E. 2000 Falco
- ① Caproni-Reggiane R.E. 2001

## CESSNA (U.S.A.)

- ① Cessna AT-8 and AT-17 Bobcat
- ① Cessna Crane I (R.C.A.F.)

## CHANCE VOUGHT (U.S.A.)

- ☐ Chance Vought Chesapeake I (see VOUGHT-SIKORSKY)
- ☐ Chance Vought Corsair (see VOUGHT-SIKORSKY)
- ① Chance Vought F4U-2 Corsair II
- \*① **Chance Vought F4U-4 Corsair**
- ☐ Chance Vought Kingfisher (see VOUGHT-SIKORSKY)

## COMMONWEALTH (AUSTRALIA)

- ① Commonwealth Boomerang
- ① Commonwealth CA-15
- ① Commonwealth Wirraway

## CONSOLIDATED VULTEE (U.S.A.)

- ③ Consolidated Vultee Catalina I
- ③ Consolidated Vultee Catalina III (PBY-5A)
- ③ Consolidated Vultee PB2Y-1 & PB2Y-3 Coronado
- ① Consolidated Vultee PB2Y-2 Coronado II
- ② Consolidated Vultee PB2Y-5H & PB2Y-3R Coronado
- ② Consolidated Vultee BritishType 28 & US PBY-3
- ② Consolidated Vultee B-32 Dominator - Split
- ③ Consolidated Vultee Liberator I
- ③ Consolidated Vultee Liberator III & IV
- ③ Consolidated Vultee B-24J Liberator
- ③ Consolidated Vultee PB4Y-1 Liberator
- ③ Consolidated Vultee RY-3 Liberator IX
- ③ Consolidated Vultee P4Y-1 Liberator
- ③ Consolidated Vultee PB4Y-2 Privateer
- ☐ Consolidated Vultee Stinson (see STINSON)
- ☐ Consolidated Vultee L-5 Sentinel I (see STINSON)
- ☐ Consolidated Vultee Vengeance (see VULTEE)

## CURTISS (U.S.A.)

- ③ Curtiss C-76 Caravan
- ① Curtiss SBC-4 Cleveland I (R.A.F.)
- ① Curtiss SNC-1 Falcon
- ① Curtiss 75-A Hawk
- ① Curtiss A-25 Helldiver
- ① Curtiss SB2C-1 Helldiver I
- \*① **Curtiss SB2C-4 Helldiver**
- ① Curtiss AT-9 Jeep
- ① Curtiss Kittyhawk II (R.A.F.)
- ① Curtiss Mohawk IV (R.A.F.)
- ① Curtiss O-52 Owl I
- ① Curtiss SOC-1 Seagull
- ① Curtiss SO3C-1 Seagull I
- \*① **Curtiss SC-1 Seahawk**
- ① Curtiss Royal NavySeamew I (SO3C-1 Seagull I)
- ① Curtiss P-40 Tomahawk I (R.A.F.)
- ① Curtiss P-40 Tomahawk II (R.A.F.)
- \*① **Curtiss P-40L Warhawk**

## CURTISS-WRIGHT (U.S.A.)

- ② Curtiss-Wright C-46 Commando
- ① Curtiss-Wright CW 21B (Dutch)

## DE HAVILLAND (GREAT BRITAIN)

- ② De Havilland 86B
- ① De Havilland Dominie I
- ① De Havilland 84A Dragon (Iraq)
- ① De Havilland Hornet I & Sea Hornet XX
- ① De Havilland Mosquito II
- ① De Havilland Mosquito III & IV (Civil)
- ① De Havilland Mosquito I
- ① De Havilland Mosquito PR (IX)
- \*① **De Havilland Mosquito XVI**
- ① De Havilland Mosquito XVIII
- ① De Havilland Mosquito 34 and 35
- ① De Havilland Mosquito 36



- ① De Havilland 94 Moth Minor
- ① De Havilland Sea Hornet XX
- ① De Havilland Sea Mosquito 33
- ① De Havilland Tiger Moth
- ① De Havilland 82C Tiger Moth (Canadian)
- ① De Havilland Vampire I and II

## DEWOITINE (FRANCE)

- ① Dewoitine D 520

## D.F.S. (GERMANY)

- ① 230A-1 glider

## DORNIER (GERMANY)

- ② Dornier Do 17P
- ② Dornier Do 17Z
- ② Dornier Do 18K
- ② Dornier Do 24
- ③ Dornier Do 26K
- ② Dornier Do 215
- ② Dornier Do 217E
- ② Dornier Do 217J
- ② Dornier Do 217K-1 and K-2 - Split
- ② Dornier Do 217M and N - Split
- ② Dornier Do 335 - Split

## DOUGLAS (U.S.A.)

- ② Douglas R.A.F. Boston III & Havoc II (DB-7A)
- ② Douglas C-33 (DC-2)
- ② Douglas C-47 Dakota (DC-3)
- \*① **Douglas SBD-3 Dauntless**
- ① Douglas BTD-1 Destroyer
- ② Douglas TBD-1 Devastator
- ② Douglas C-74 Globemaster - Split
- ② Douglas Havoc I (R.A.F.)
- \*② **Douglas A-20C Havoc**
- ② Douglas P-70 Havoc
- ② Douglas A-26 Invader -Split
- ② Douglas XB-42 Mixmaster - Split
- ② Douglas R3D-1 & R3D-2
- ③ Douglas C-54 Skymaster (DC-4)
- ② Douglas C-47B Skytrain Amphibian

## FAIRCHILD (U.S.A.)

- ① Fairchild R.A.F. Argus I (C-61)
- ① Fairchild PT-26 Cornell I (R.C.A.F.)
- ① Fairchild UC-86 Forwarder
- ① Fairchild At-13 Yankee Doodle
- ① Fairchild AT-14 and AT-21 Yankee Doodle
- ① Fairchild M-62 (Norwegian)
- ② Fairchild Model 91 Amphibian
- ③ Fairchild C-82 Packet

## FAIREY (GREAT BRITAIN)

- ① Fairey Albacore I
- ① Fairey Barracuda I & II

- ① Fairey Barracuda V
- ① Fairey Battle I
- ① Fairey Battle Trainer
- \*① **Fairey Firefly I**
- ① Fairey Firefly IV
- ① Fairey Fulmar I
- ① Fairey Seafox I
- ② Fairey Spearfish I - split
- ① Fairey Swordfish I
- \*① **Fairey Swordfish III**

## FAIREY (BELGIUM)

- ① Fairey Firefly II
- ① Fairey Fox VII

## FIAT (ITALY)

- ② Fiat BR 20 Cicogna
- ① Fiat G 50 Falco
- ① Fiat CR 42 Freccia
- ② Fiat RS 14

## FIESELER (GERMANY)

- ① Fieseler Fi 103 Flying Bomb
- ① Fieseler Fi 156C Storch
- ① Fieseler Fi 167

## FLEET (CANADA)

- ① Fleet (Consolidated ) BT-7
- ① Fleet Finch (R.C.A.F.)
- ① Fleet Fort (R.C.A.F.)

## FLEETWINGS (U.S.A.)

- ① Fleetwings BT-12 Sophomore

## FOCKE WULF (GERMANY)

- ② Focke Wulf Fw 58 Weihe
- ① Focke Wulf Fw 187
- ① Focke Wulf Fw 189
- ① Focke Wulf Fw 190A-3
- \*① **Focke Wulf Fw 190A-4**
- \*① **Focke Wulf Fw 190D**
- ③ Focke Wulf Fw 191A
- ③ Focke Wulf Fw 200 Condor
- ③ Focke Wulf Fw 200K Kurier
- ① Focke Wulf Ta 152H

## FOKKER (HOLLAND)

- ① Fokker C-11W
- ① Fokker D-21
- ② Fokker G-1
- ② Fokker T-4
- ② Fokker T-5
- ② Fokker T-8-W

## FUJI KOKUKI K.K. (JAPAN)

- ① MXY 7 Baka (Jinari Thunderclap)



## GENERAL AIRCRAFT (GREAT BRITAIN)

- ② General Aircraft Hamilear I glider
- ② General Aircraft Hamilear X - Split
- ① General Aircraft Hotspur II glider
- ① General Aircraft Owllet

## GLOSTER (GREAT BRITAIN)

- ① Gloster E 28/39
- ① Gloster F 9/37
- ① Gloster Meteor III
- ① Gloster Meteor IV

## GOTHA (GERMANY)

- ② AGotha Go 242 glider

## GRUMMAN (U.S.A.)

- ① Grumman TBF-1 Avenger (British Tarpon I)
- ① Grumman F8F-1 Bearcat
- ① Grumman J2F-4 Duck
- ① Grumman OA-9 Goose I (R.A.F.)
- ① Grumman J4F-1 Gosling I (R.A.F.)
- \*① **Grumman F6F-3 Hellcat**
- ① Grumman Martlet I (Royal Navy)
- ② Grumman F7F-1 Tigercat - Split
- ① Grumman F4F-4 Wildcat IV & V
- \*① **Grumman FM-2 Wildcat VI**

## HALL (U.S.A.)

- ② Hall PH-3

## HANDLEY PAGE (GREAT BRITAIN)

- ③ Handley Page Halifax I & II
- ③ Handley Page Halifax II Series I & 1A
- ① Handley Page Halifax VI
- ③ Handley Page Halifax VIII
- ② Handley Page Hampden I & Herford
- ② Handley Page Hastings I - Split

## HAWKER (GREAT BRITAIN)

- ① Hawker Fury (Yugoslavian)
- ① Hawker Henley I
- ① Hawker Hind Trainer
- ① Hawker Horsley (Greek)
- ① Hawker Hurricane I
- \*① **Hawker Hurricane II**
- ① Hawker Hurricane IIB
- ① Hawker Hurricane IID
- ① Hawker Hurricane II RP
- ① Hawker Nistr (Audax) (Iraq)
- ① Hawker Sea Fury X
- ① Hawker Tempest II
- \*① **Hawker Tempest V**
- ① Hawker Tornado I
- ① Hawker Typhoon I
- ① Hawker Typhoon I RP

## HEINKEL (GERMANY)

- ② Heinkel He 59
- \*① **Heinkel He 60**
- ② Heinkel He 111K Mk Va
- ② Heinkel He 111H AE
- ① Heinkel He 113
- ① Heinkel He 114
- ② Heinkel He 115
- ① Heinkel He 162A
- ③ Heinkel He 177
- ② Heinkel He 219A - Split

## HENSCHEL (GERMANY)

- ① Henschel Hs 126
- ① Henschel Hs 129

## HOWARD (U.S.A.)

- ① Howard Gh-1 Nightingale

## INTERSTATE (U.S.A.)

- ① Interstate L-6

## IKARUS (Yugoslavia)

- ① Ikarus IK-2

## JUNKERS (GERMANY)

- ② Junkers Ju 52/3m
- ③ Junkers Ju 86K
- ② Junkers Ju 86P
- ① Junkers Ju 87B
- ① Junkers Ju 87D
- ① Junkers Ju 87D (anti-tank)
- ② Junkers Ju 88A-6
- ② Junkers Ju 88C
- ② Junkers Ju 88G - Split
- ② Junkers Ju 188
- ② Junkers Ju 287 - Split
- ② Junkers Ju 290
- ③ Junkers Ju 352
- ② Junkers Ju 388 - Split

## KAWANISHI (JAPAN)

- ② Kawanishi Navy 2 (Emily) - Split
- ① Kawanishi Navy Shiden (George)
- ② Kawanishi Navy 97 (Mavia) - Split

## KAWASAKI (JAPAN)

- ① Kawasaki KB 97
- ① Kawasaki Army 99 (Lily)
- ① Kawasaki Army 2 (Nick)
- ① Kawasaki Army 03 (Tony)

## KELLETT (U.S.A.)

- ① Kellett YO-60

## KOOLHOVEN (HOLLAND)

- ① Koolhoven FK 52
- ① Koolhoven FK 58

## LIORE ET OLIVIER (FRANCE)

- ② Liore et Olivier Le O 45B4

## LOCKHEED (U.S.A.)

- ① Lockheed C-40 (Model 12)
- ① Lockheed 212A (Dutch)
- ③ Lockheed C-69 Constellation
- ① Lockheed C-37 Electra
- ② Lockheed PV-2 Harpoon - Split
- ② Lockheed Hudson I (R.A.F.)
- ② Lockheed Hudson V (R.A.F.)
- ② Lockheed A-29 Hudson
- ① Lockheed 322-61 Lightning
- ① Lockheed P-38F Lightning
- ① Lockheed P-38J and F-5 Lightning
- \*① **Lockheed P-38L & F5-E Lightning**
- ① Lockheed P-38M & F5-G Lightning
- ② Lockheed C-56 Lodestar
- ③ Lockheed P2V-1 Neptune
- ① Lockheed P-80A Shooting Star
- ② Lockheed Ventura I (R.A.F.)
- ② Lockheed PV-1 Ventura

## MACCHI (ITALY)

- ① Macchi C200 Saetta
- ① Macchi C202

## MARTIN (U.S.A.)

- ② Martin 139 (Dutch)
- ② Martin 166 (Dutch)
- ② Martin 167-W
- ② Martin Baltimore I (R.A.F.)
- ② Martin A-30 & Baltimore III (R.A.F.)
- ② Martin B-26B Marauder I
- \*② **Martin B-26C Marauder**
- ② Martin B-26C & Marauder II (R.A.F.)
- ② Martin PBM-3 Mariner III
- ② Martin PBM-3S & PBM-5E Mariner
- ② Martin JRM-1 Mars

## MARTIN-BAKER (GREAT BRITAIN)

- ① Martin-Baker M.B.5

## MESSERSCHMITT (GERMANY)

- ① Messerschmitt Me 108B Taifun
- ① Messerschmitt Me 109E
- ① Messerschmitt Me 109F
- ① Messerschmitt Me 109G
- \*① **Messerschmitt Me 109G-16**
- ② Messerschmitt Me 110 & Jaguar
- ① Messerschmitt Me 110G
- \*① **Messerschmitt Me 163B**

- ① Messerschmitt Me 210A-1
- \*① **Messerschmitt Me 262A-1**
- ① Messerschmitt Me 262A-2
- ② Messerschmitt Me 323 Gigant
- ① Messerschmitt Me 410

## MILES (GREAT BRITAIN)

- ① Miles Magister I
- ① Miles Magister II
- ① Miles M-20
- ① Miles M-28
- ① Miles M-28-4
- ① Miles Martinet I
- ① Miles Master II
- ① Miles Master III
- ① Miles Mentor I
- ① Miles M.38 Messenger I
- ① Miles Monitor II - Split

## MITSUBISHI (JAPAN)

- ② Mitsubishi OB-O1
- ② Mitsubishi Army OB-97
- ② Mitsubishi Army 00 (Dinah)
- ① Mitsubishi Navy 00 (Hamp)
- ① Mitsubishi Navy Raden 11 & 21 (Jack)
- ① Mitsubishi Army KB-98 Karigane IIM
- ② Mitsubishi Navy OB-96-4A (Nell)
- ② Mitsubishi KB-96-1 Otori
- ② Mitsubishi Army Type 4 Model 1 (Peggy) - Split
- ① Mitsubishi Navy 02 (Rufe)
- ① Mitsubishi Navy S-00 (Zeke)
- \*① **Mitsubishi Navy 0 (Zeke 52)**

## MONOCOUCPE (U.S.A.)

- ① Monocoupe L-7A

## MORANE SAULNIER (FRANCE)

- ① Morane Saulnier MS 406C-1

## NAKAJIMA (JAPAN)

- ① Nakajima Navy G-96
- ① Nakijima Navy S-92-2
- ① Nakijima Army S-97
- ① Nakijima Army 4 (Frank)
- ② Nakijima Army 100 (Helen) Split
- ① Nakijima Navy Gekko (Irving)
- ① Nakijima Navy Tenzan (Jill)
- ① Nakijima Navy Saiuin (Myrt)
- ① Nakijima Army 01 (Oscar)
- ① Nakijima Army 2 (Tojo)

## NAVAL AIRCRAFT FACTORY (U.S.A.)

- ② Naval Aircraft Factory N3N-1 Canary
- ③ Naval Aircraft Factory PBN-1 Catalina V (Nomad)

## NOORDUYN (CANADA)

- ① Noorduyn Norseman (R.C.A.F.)
- ① Noorduyn C-64A Norseman

## NORTH AMERICAN (U.S.A.)

- ① North American Harvard I (R.A.F.)
- ① North American Harvard II (R.A.F.)
- ② North American R.A.F. Mitchell III (B-25C)
- ② North American B-25G & B-25H Mitchell
- ① North American Mustang I (R.A.F.)
- ① North American Mustang IA (R.A.F.)
- \*① **North American A-36 Mustang**
- \*① **North American P-51B and P-51C Mustang III**
- \*① **North American P-51D Mustang**
- ① North American P-51E Mustang IV
- \*① **North American P-51H Light Mustang**
- \*① **North American P-82 Twin Mustang**
- ① North American O-47B
- ① North American Yale I (French)

## NORTHROP (U.S.A.)

- ② Northrop P-61A Black Widow - Split
- ① Northrop N3PB (Norwegian)
- ② Northrop F-15 Reporter - Split

## PERCIVAL (GREAT BRITAIN)

- ① Percival Prentice I
- ① Percival Proctor I
- ① Percival Proctor IV
- ① Percival Q4 & Q6 Petrel

## PIAGGIO (ITALY)

- ② Piaggio P. 32bis
- ③ Piaggio P. 108-B

## PIPER (U.S.A.)

- ① Piper O-59 "Grasshopper" (L-59A Patrol)
- ① Piper TG-8 glider

## POTEZ (FRANCE)

- ② Potez 63
- ① Potez 63-11

## P.Z.L. (POLAND)

- ② Los
- ① Mewa
- ① P.24
- ① Sum

## REPUBLIC (U.S.A.)

- ① Republic AT-12
- ① Republic P-43 Lancer (Chinese)
- ① Republic P-47B Thunderbolt
- \*① **Republic P-47D Thunderbolt**
- \*① **Republic P-47D-25 Thunderbolt II**
- \*① **Republic P-47N-5 Thunderbolt**

## RUSSIAN STATE FACTORIES (U.S.S.R)

- ② DB-3 & DB-3F
- ① I-15 Chato
- ① I-16 Rata
- ① I-17
- ① IL-2C Stormovik (B Sch)
- ① IL-3 Stormovik
- ① LA-5
- ① LAGG-3
- ② MBR-2
- ① I-61 (MIG-3)
- ② PE-2
- ① PE-3
- ① R-10
- ② SB-2 Katiuska
- ② SB-RK
- ① SU-2 (BB-1)
- ③ TB-3
- ② TB-7
- ① I-26 (YAK-1)
- ① BB-22 (YAK-4)
- ① YAK-9

## RYAN (U.S.A.)

- ① Ryan PT-16 and PT-20
- ① Ryan PT-25
- ① Ryan FR-2 Fireball
- ① Ryan PT-21 and PT-22 Recruit

## SASEBO (JAPAN)

- ① Sasebo Navy OO (Pete)

## SAUNDERS-ROE (GREAT BRITAIN)

- ② Saro London
- ② Saro Lerwick

## SAVOIA MARCHETTI (ITALY)

- ② Savoia Marchetti S.M. 79 Sparviero
- ② Savoia Marchetti S.M. 81 Pipistrello
- ② Savoia Marchetti S.M. 82 Cangaru
- ② Savoia Marchetti S.M. 79B (Rumanian)
- ② Savoia Marchetti S.M. 94

## SHORT (GREAT BRITAIN)

- ② Short Seaford I - Split
- ② Short Shetland I - Split
- ③ Short Stirling I
- ③ Short Stirling IV
- ② Short Sturgeon I - Split
- ③ Short Sunderland I
- ③ Short Sunderland III

## SIEBEL (GERMANY)

- ① Siebel Si 204D

## SIKORSKY (U.S.A.)

- ① Sikorsky R-4B Hoverfly I helicopter
- ① Sikorsky HOS-1 Hoverfly II helicopter

## SLINGSBY (GREAT BRITAIN)

- ② Slingsby Hengist I glider - Split
- ① Slingsby Kirby Cadel glider

## SPARTAN (U.S.A.)

- ① Spartan NP-1

## ST. LOUIS (U.S.A.)

- ① St. Louis PT-15

## STEARMAN (U.S.A.)

- ① Stearman PT-13A Caydet

## STINSON

- ① Stinson AT-19 Reliant I (Royal Navy)
- ① Stinson L-5 Sentinel
- ① Stinson O-49A Vigilant I

## SUPERMARINE

See VICKERS (GREAT BRITAIN)

## TAYLORCRAFT (U.S.A.)

- ① Taylorcraft L-57A Grasshopper
- ① Taylorcraft TG-6 glider
- ☐ See Auster IV (BritishTaylorcraft D)

## TIMM (U.S.A.)

- ① Timm N2T-1 Tutor

## VICKERS ARMSTRONGS (GREAT BRITAIN)

- ① Vickers Armstrongs (Supermarine) Type 322
- ① Vickers Armstrongs Type 432
- ① Vickers Armstrongs Seafang 32
- ① Vickers Armstrongs Seafire III
- ① Vickers Armstrongs Seafire 46 & 47
- \*① **Vickers Armstrongs Sea Otter I & II**
- \*① **Vickers Armstrongs Spiteful XIV & XV**
- ① Vickers Armstrongs Spitfire II
- ① Vickers Armstrongs Spitfire V Modified
- ① Vickers Armstrongs Spitfire VII
- \*① **Vickers Armstrongs Spitfire VIII**
- ① Vickers Armstrongs Spitfire IX
- ① Vickers Armstrongs Spitfire IV & XI
- ① Vickers Armstrongs Spitfire XII
- \*① **Vickers Armstrongs Spitfire XIV**
- \*① **Vickers Armstrongs Spitfire XVI**
- ① Vickers Armstrongs Spitfire 21 & 22
- ② Vickers Armstrongs Stranraer I
- ① Vickers Armstrongs Walrus I

- ② Vickers Armstrongs Warwick Transport
- ② Vickers Armstrongs Warwick I - Split
- ② Vickers Armstrongs Warwick III - Split
- ③ Vickers Armstrongs Warwick V
- ② Vickers Armstrongs Wellesley IA
- ② Vickers Armstrongs Wellesley II
- ② Vickers Armstrongs Wellington II & III
- ② Vickers Armstrongs Wellington XIII & XIV - Split
- ③ Vickers Armstrongs Windsor I

## VOUGHT-SIKORSKY (U.S.A.)

- ① Vought-Sikorsky Chesapeake I (Royal Navy)
- ① Vought-Sikorsky Corsair I (Royal Navy)
- ① Vought-Sikorsky OS2U-3 Kingfisher I (Royal Navy)

## VULTEE (U.S.A.)

- ① Vultee BT-13A Valiant
- ① Vultee Vanguard I (Chinese)
- ① Vultee Vengeance I (R.A.F.)
- ☐ Vultee L-56A Sentinel (See Stinson)
- ☐ Vultee O-49A Vigalent I (See Stinson)

## V-I FLYING BOMB

see FIESELER (GERMANY)

## WACO (U.S.A.)

- ① Waco PT-14
- ② Waco CG-13A glider
- ② Waco CG-4A Hadrian I glider

## WESTLAND (GREAT BRITAIN)

- ① Westland Lysander I
- ② Westland Welkin I & II - Split
- ① Westland Whirlwind I

## WICKO (GREAT BRITAIN)

- ① Wicko Warferry I

## YOKOSUKA (JAPAN)

- ② Yokosuka Navy Ginka & Hakko ,(France) - Split
- ① Yokosuka Navy Suisei (Judy)
- ① Yokosuka Navy Model 33 Suisei (Judy 33)

For A Printed Copy Of This List, Please Send \$1 US  
Cash To:

**Phil Koopman**  
**2805 Hunt Club Lane**  
**Orlando, FL 32826-3909**  
**U.S.A.**

# Printing Problems

The Adobe Acrobat™ system of readers supports IBM-PC type computers running DOS and Windows. FREE readers are also available for the Apple Macintosh and Sun “SPARC” Workstations running under the Unix operating system. If your software source does not have the correct reader for your system, they can be obtained via Internet from: <ftp.adobe.com>

Printing is supported for raster-type printers, like an HP LaserJet, and Postscript printers. Printing may be done in either monochrome or color, depending on the printer you have available. Please note that some of the Adobe Readers, like Version 1.0 for DOS, may not support color printing, or only support color printers in the monochrome print mode.

When printing to any inkjet printer, make sure you use a print buffer so the printer receives a constant stream of data. This prevents minor gaps and blurs if the printer has to wait for more data. This is particularly important for color inkjet printers.

For Windows printing, make sure to use the Print Manager for print buffering. If you have difficulty printing under Windows, make sure that you have sufficient free disk space for the buffer files created by the Windows Print Manager. As an example, each printed color page requires about 500-kbytes of disk space — during image processing, the disk requirements can be greater than 4 Mbytes for temporary files.

## Not Enough Disk Space

In extreme cases, not enough disk space shows as either a terminated print — the program appears to print, but nothing happens — or error messages like “Insufficient Memory” or “Not Enough Memory To Print.” Some versions of Adobe Acrobat can give a General Protection Fault in “module unknown” and terminate while attempting to print. Free up space on your hard drive by deleting unused files or programs.

Or, try printing a single page at a time. Remember, processing color images takes a great deal of disk space for the temporary files. You may need to have 10-12 Mbytes of free disk space for the temporary files and the Print-Manager’s, or print buffer’s, image files for a non-Postscript printer.

## Extremely “Thin” Lines

The illustrations are drawn with “thin” lines to fit a wide range of printers. The Adobe Acrobat print routines set these thin, or hairlines, to the precision of the printer you use. Lines printed on a 300-dpi laser printer will be one “dot” wide. Printing the same image on a 600-dpi printer may give extremely thin lines; 1/600th of an inch wide. If you use a high-resolution printer, try setting your printer to a lower resolution — this automatically widens the thin lines.

[Click Here To Return](#)